

PMG200

Elevator Traction Machine
Machines de traction ascenseurs



Voltage	380 V	Tension
Suspension	1:1	Suspension
Motor type	PM	Type de moteur
Brake	DC110V 1.3 A	Frein
Weight	360 kg	Poids
Max. Static Load	5 500 kg	Charge stat. maxi.

Horizontal type is optional

Position horizontale possible

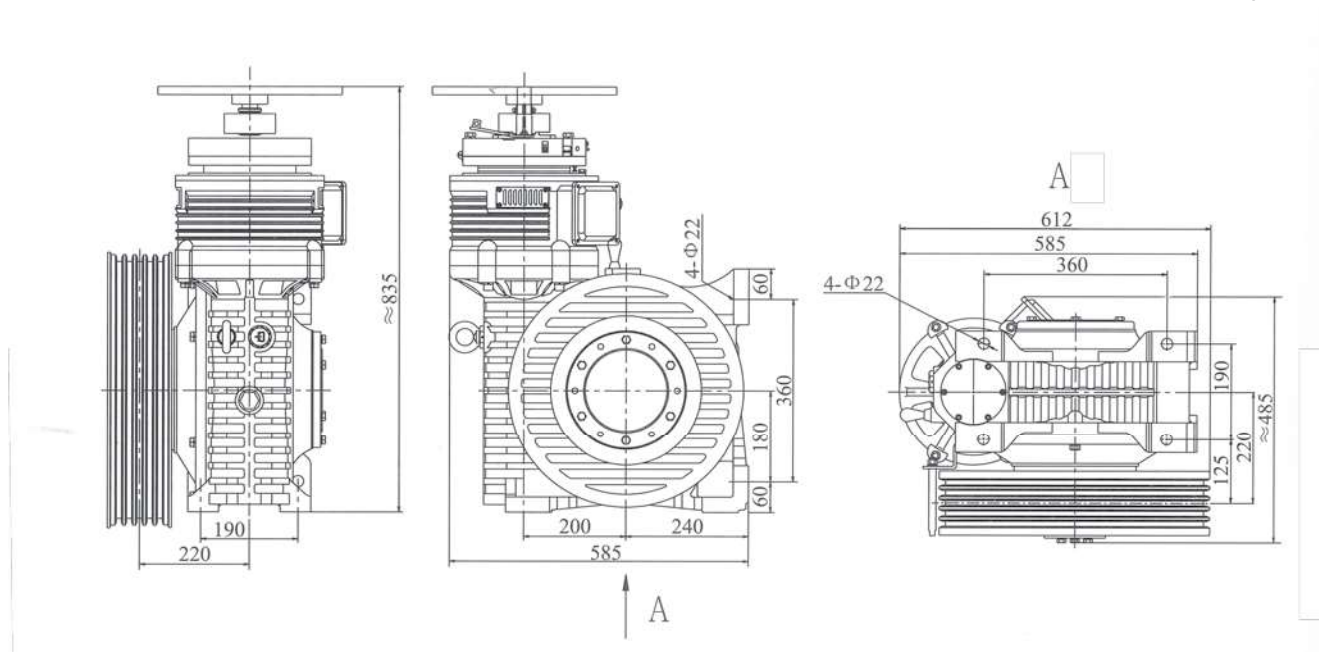

PMG

Load Charge (kg)	Speed Vitesse (m/s)	Height Course (m)	Ratio Ratio	ø Sheave ø Poulie (mm)	Rope sheave Câbles (mm)	Power Puissance (kW)	Rated speed Vitesse de rotation (rpm)	Frequency Fréquence (Hz)	Pole Pôle	INS. class	IP code
800	1,0	≤ 80	75:2	Ø 530	5XØ13X20	6,8	1400	93,3	8	F	IP21
800	1,6	≤ 80	47:2	Ø 530	5XØ13X20	10,5	1400	93,3	8	F	IP21
800	1,75	≤ 80	47:2	Ø 530	5XØ13X20	11,2	1500	100	8	F	IP21
800	2	≤ 80	61:3	Ø 530	5XØ13X20	12,8	1500	100	8	F	IP21
630	0,6 to 1,0	≤ 80	75:2	Ø 530	5XØ*9/11X16	5,9	1400	95,3	8	F	IP21

* Groove V35°. Incremental encoder.
* gorges V35°. Codeur incrémental.