

# FYJ180

*Elevator Traction Machine*  
*Machines de traction ascenseurs*

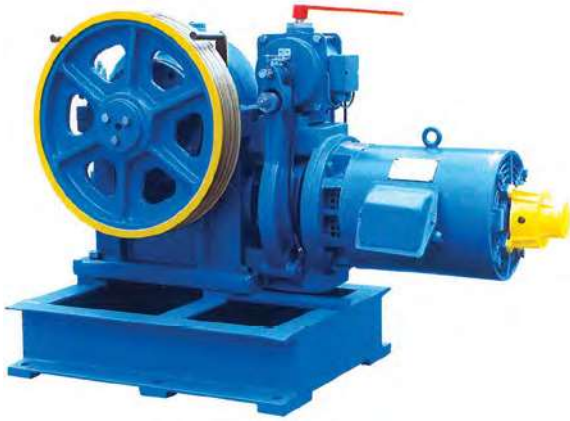

Suspension	<b>1:1</b>	Suspension
Control	<b>VVVF</b>	Contrôle
Brake (DZE-9E)	<b>DC110V 1 A</b>	Frein (DZE-9E)
Weight	<b>430 kg</b>	Poids
Max. Static Load	<b>3 500 kg</b>	Charge stat. maxi.

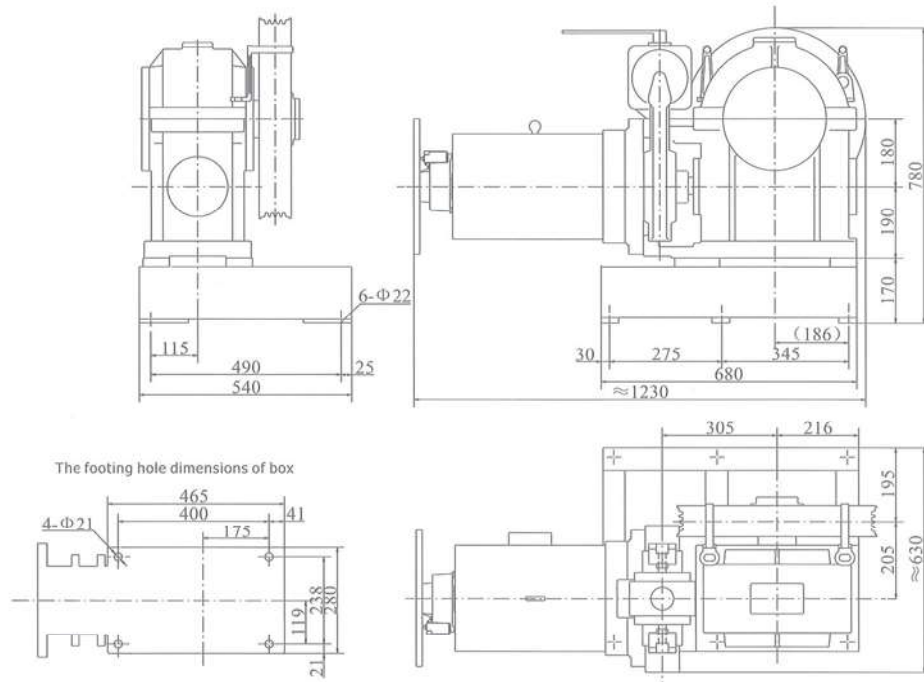

Load Charge	Speed Vitesse	Ratio	ø Sheave ø Poulie	Rope sheave Câbles	Power Puissance	Pole
(kg)	(m/s)		(mm)	(mm)	(kW)	
630	0,75	47:1	Ø 480	4X12(Pitch 18)	5,5	4
630	1,0	36:1	Ø 480	4X12(Pitch 18)	6,4	4
630	1,5	47:2	Ø 480	4X12(Pitch 18)	9	4

Right sheave type is optional.  
Incremental encoder.  
Poulie à droite possible  
Codeur incrémental.